

CUSTOMER TECHNICAL MEMO # 270

Subject 443-L ecoFRAMEplus Sash Adaptor **Date:** 2)th July 2016

Author: Product Development Team

We are very pleased to advise the release of a new sash adaptor for ecoFRAMEplus to suit our 443 Awning Sash.

This new adaptor aligns with 443-H Head Section and clips into the jambs and sill providing a consistent sash rebate when used with 101.6mm ecoFRAMEplus framing.

This new section will be stocked in our Adelaide Branch.

Please note this Technical Memo has been formatted to allow you to easily slot new pages into your current Technical Manual when your printer is set to double sided printing.

Kind Regards
Product Development Team

This page has intentionally been left blank

Extrusions

443-L
ecoFRAMEplus
SASH ADAPTOR

Mass. 0.328 Kg/m
Anod. Per. 156
Paint Per. 100

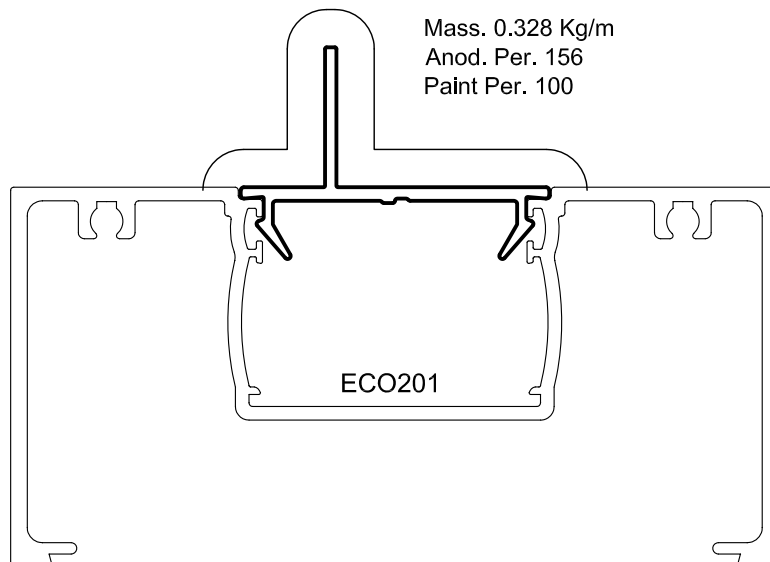

This page has intentionally been left blank

443 DG Awning in ecoFRAMEplus Head, Sill & Jamb Details

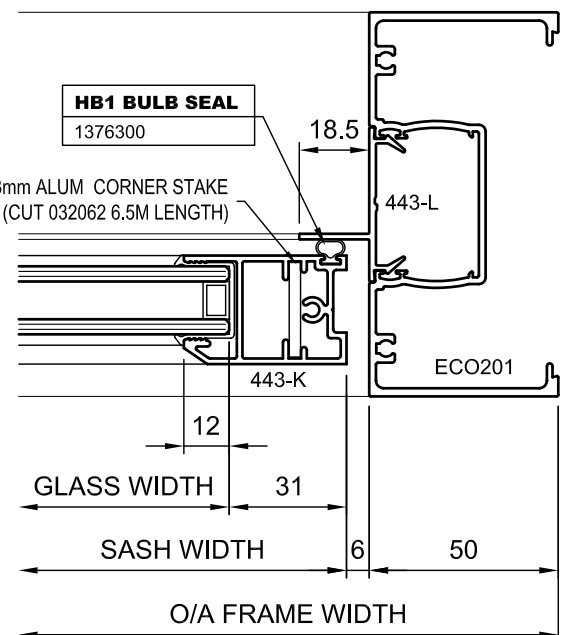
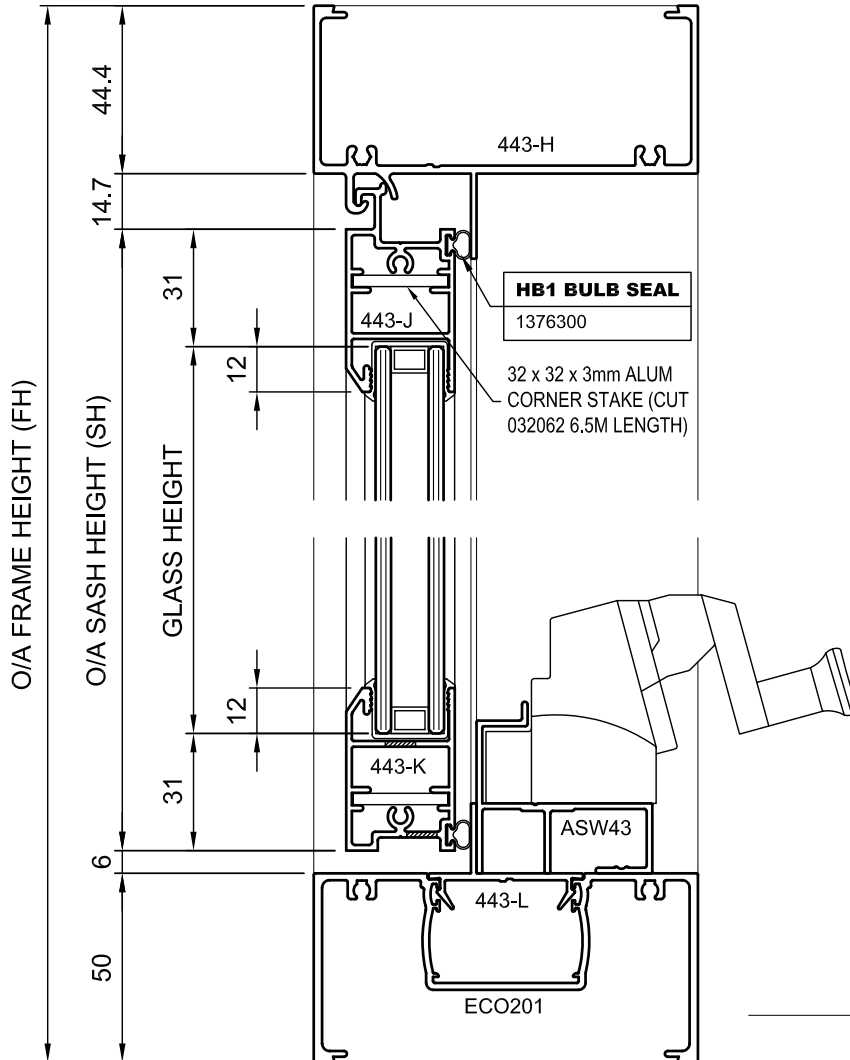

NOTE: ALL METAL TO METAL JOINTS UNLESS OTHERWISE NOTED ARE TO BE SEALED WATER TIGHT WITH A SMALL JOINT SEALER (NOT SILICONE). INCLUDE SASH ADAPTORS.

WELD ALL BULB SEAL MITRE JOINTS.

This page has intentionally been left blank

443-J Sash Top Rail Machining Details

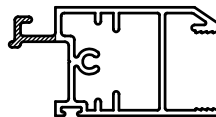
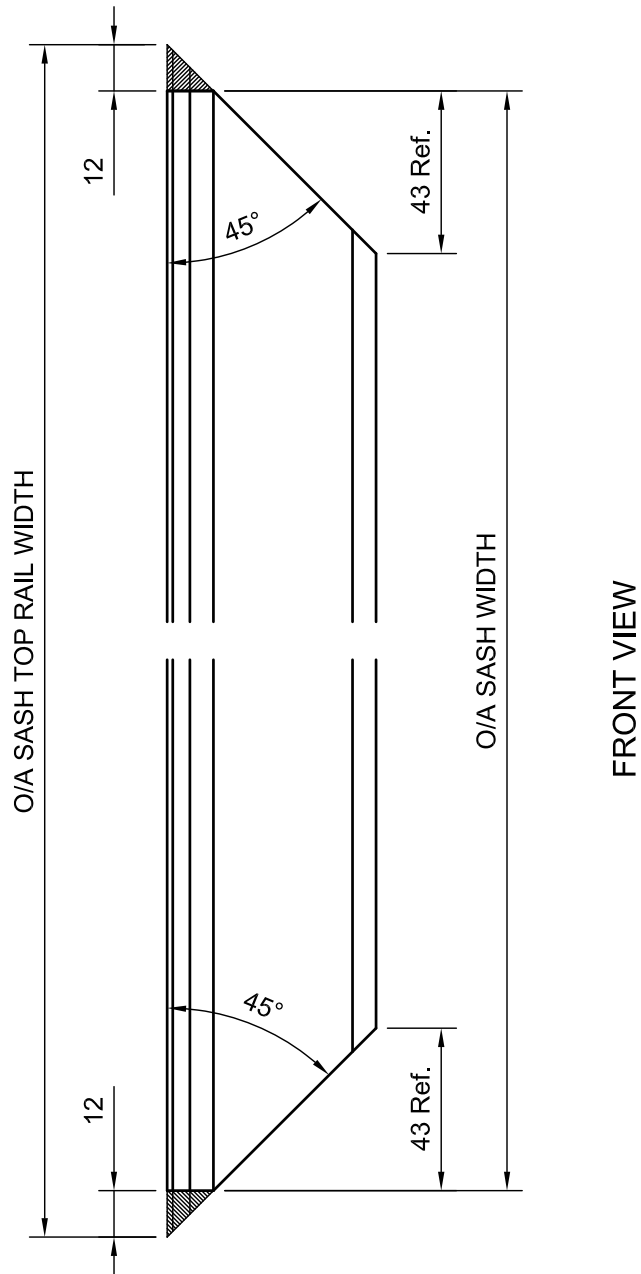

443-J

443-K Sash Bottom Rail Machining Details

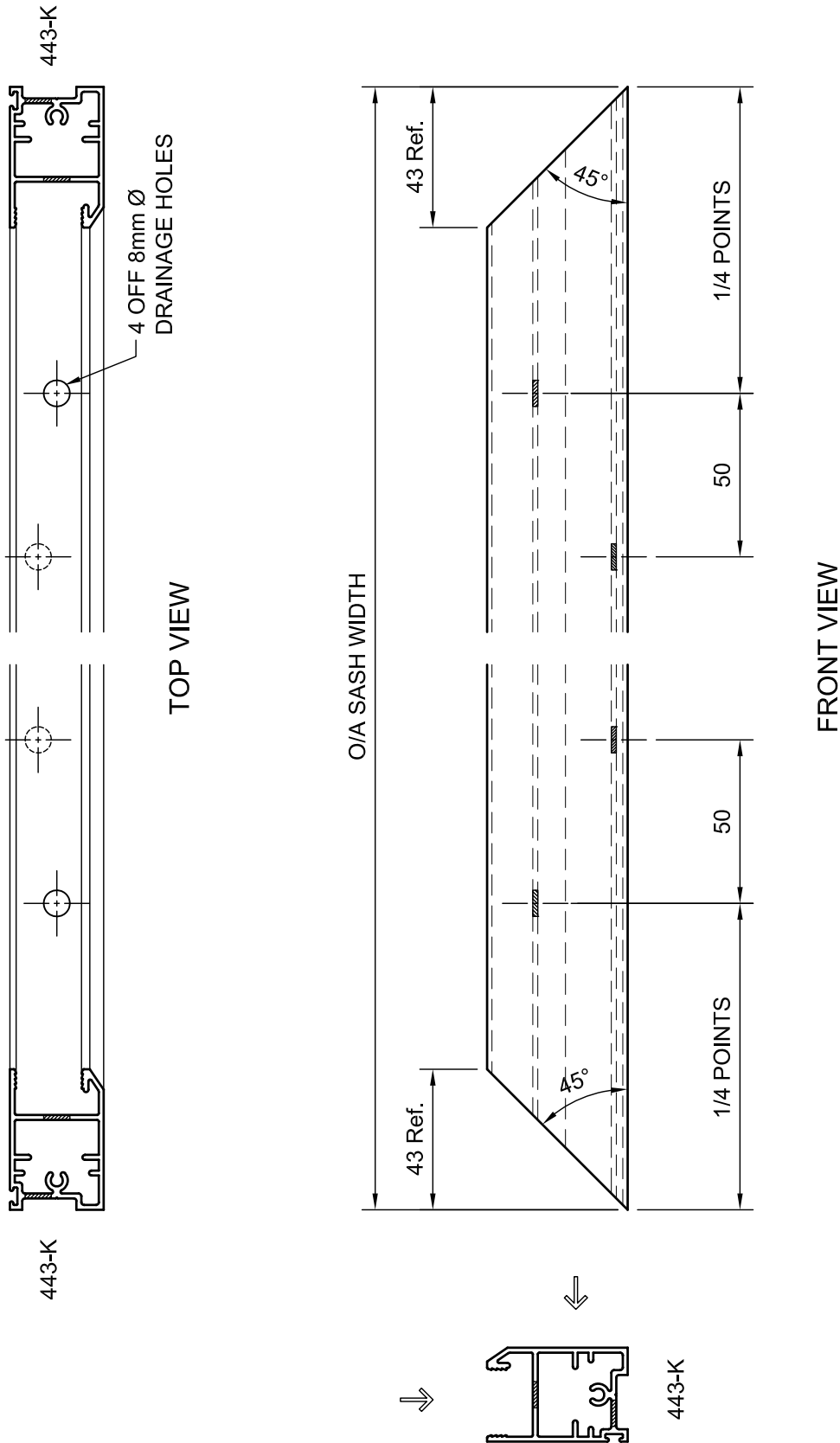

Glazing Details - 443-K Double Glazed

